

Linear Actuator

LAS Series

13. HIWIN LAS Series (4)

LAS4

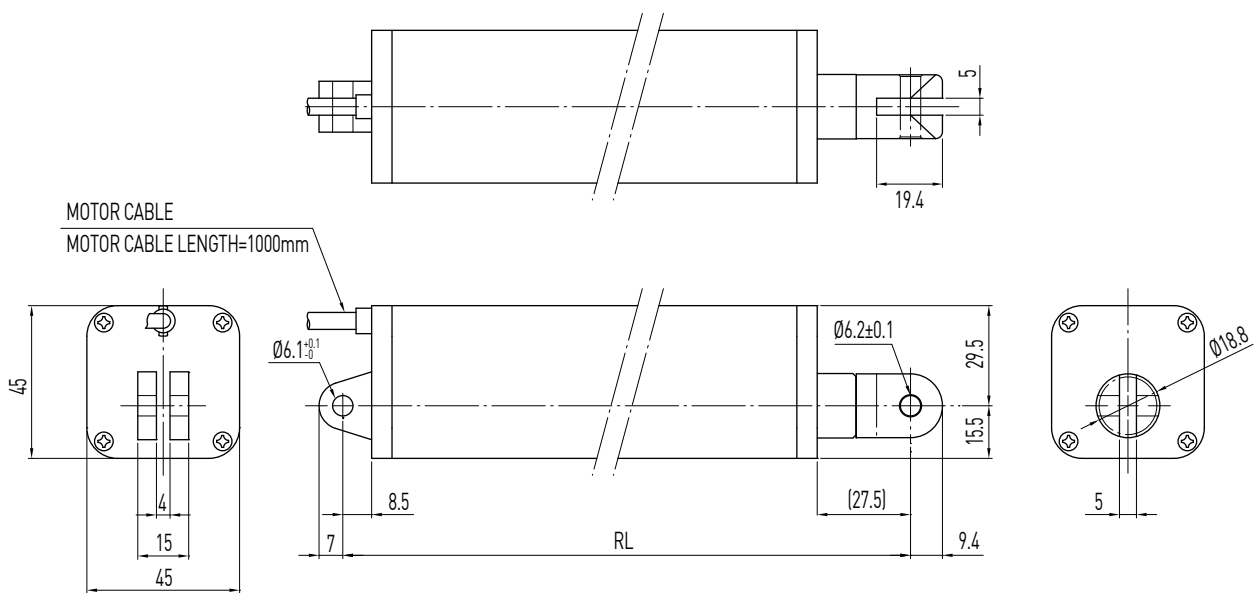

- RL = S+222.5
Stroke ≤ 300
- RL = S+272.5
Stroke > 300
- RL: Retracted length
- S: Stroke length

Table 13.1 Specifications

Screw type	ACME
Weight*	1.36kg
Protection	IP54
Compatible controller	Compatible with all controllers (*Notice the type of connector: Audio/DIN 4pin)
Working temp.	+5°C~40°C

* Stroke length 200mm

Table 13.2 Position feedback specifications (Hall Sensor)

Supply voltage	24VDC	12VDC	5VDC
Output	High level 24VDC Low level 0.2V / 10mA sink (NPN)	High level 12VDC Low level 0.2V / 10mA sink (NPN)	TTL

Option:

- (1) IP65
- (2) Hall sensor (RL = S+226, S ≤ 300 / RL = S+276, S > 300)
- (3) Plug: DIN 4PIN plug/Stereo plug/Mono plug

Table 13.3 **LAS4 Specifications**

Model	Thrust max. (N)	Pulling max. (N)	Holding max. (N)	Speed (mm / s) Load = Max. / Load = 0	Standard stroke (mm) : S					Duty cycle %	Current max. (A)		Hall Sensor Resolution (mm/pulse)
					100	150	200	250	300		12VDC	24VDC	
LAS4-1	800	800	600	10 / 15	100	150	200	250	300	10	5	2.3	0.0085
LAS4-2	300	300	200	30 / 46	100	150	200	250	300	10	6	3.6	0.02

*Min. input power = Voltage x Current max.

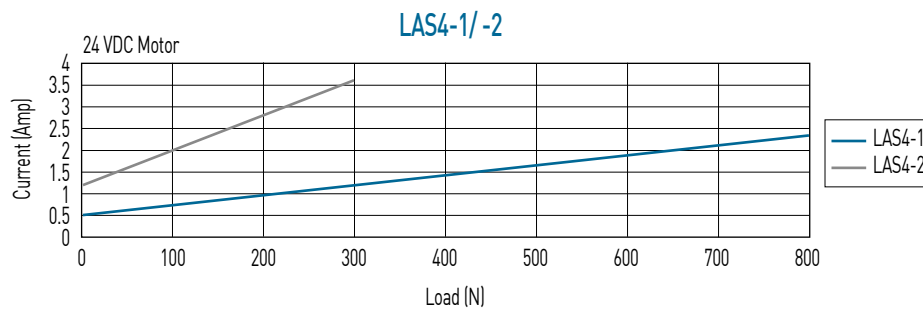
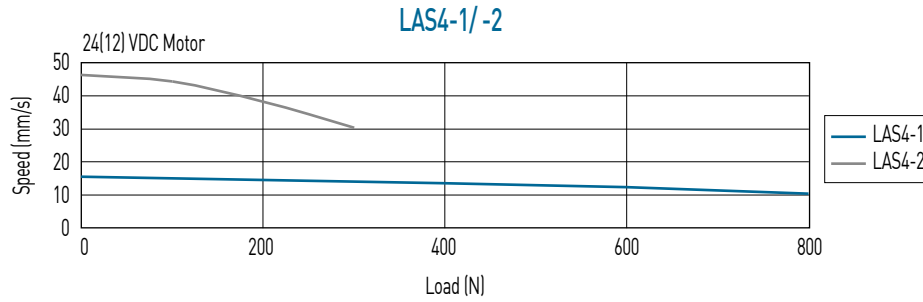

**Note: The test results are obtained by using the 24VDC power supply.

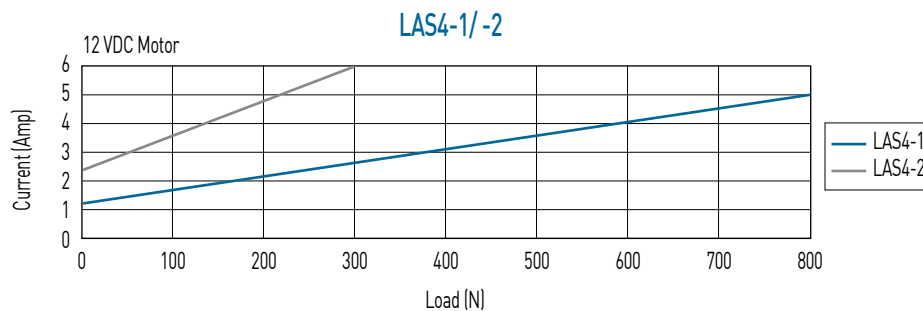

**Note: The test results are obtained by using the 12VDC power supply.

Ordering Information

